

# Capstan PinPoint III – Carbon Bee Integration

## Purpose:

Installation and integration instructions for PinPoint III and Controller-X including software/hardware requirements.

## Prerequisites:

The PinPoint III System can utilize either high-speed (500kb) or low-speed (250kb) protocols with the Carbon Bee system. The high-speed protocol is recommended to ensure the most reliable and robust communication between the two systems. The table below identifies most recent software compatibility for each system's ECU.

Protocol	PinPoint III Software	Controller-X Software	Carbon Bee CapstanAgNozzleDriver Version
250kb	v1.4.45	25.6.x	v1.2.4 or v1.14.1
500kb	v1.4.46	25.6.x	v1.14.1

\*Contact Capstan AG for PinPoint III software or Carbon Bee for Controller-X or Nozzle Driver Software.

## PinPoint III Hub and Controller-X Connections (250kb):

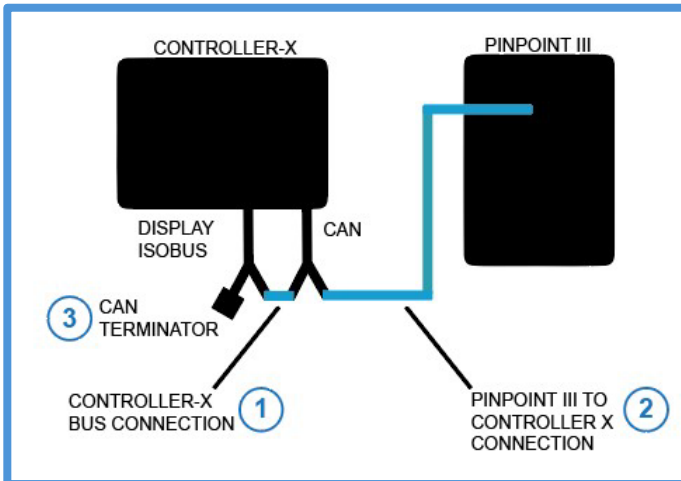

Figure 1 – System Line Drawing

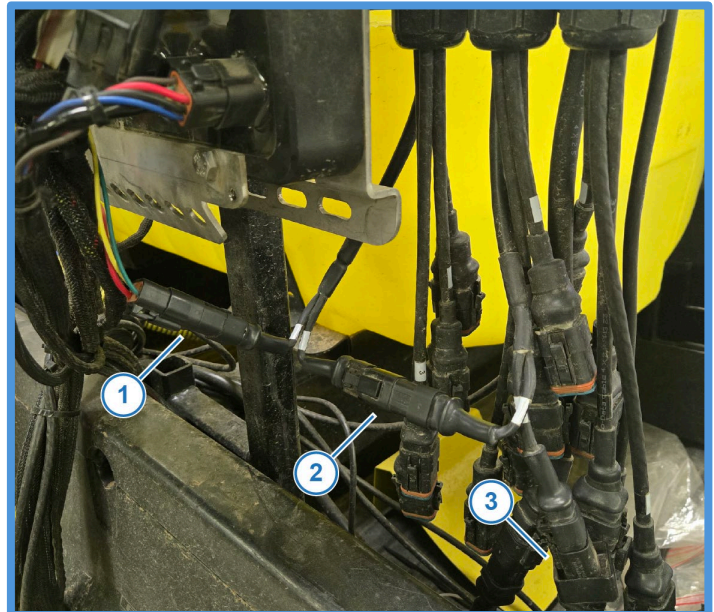

Figure 2 - PinPoint III and Controller-X Connections: (1) PinPoint III CAN to Carbon Bee CAN connection; (2) Carbon Bee Spray CAN to Carbon Bee Display ISOBUS connection; (3) CAN Terminator Connection

In **Figure 1**, there are multiple cables coming from the Controller-X with their corresponding labels. **Figure 1, Item 1** is the Display ISOBUS connection. This connection is at 250kb only and serves the Carbon Bee Virtual Terminal page shown on the sprayer's field computer. **Figure 1, Item 2** is the CAN connection and can operate at either 250kb or 500kb depending on its configuration. **Figure 2** shows the connections that are required to be made to operate the systems together using the 250kb protocol.

1. **Figure 2, Item 1** is the PinPoint III Hub. Typically, there is a CAN terminator plugged into the PinPoint III chassis harness (**Figure 2, Item 2**). This terminator will need to be removed and set aside.
2. On the CAN harness from the Controller-X, there are a male and female 4-Pin Deutsch connector. One of these will plug into where the terminator was removed (**Figure 2, Item 2**).
3. The other will plug into the Display ISOBUS connectors (**Figure 2, Item 3**).
4. The terminator removed earlier will plug into the remaining connection from the Display ISOBUS harness (**Figure 2, Item 4**).

**Note:** The Controller-X requires an ignition power source. The PinPoint III Hub can supply this from a spare VCM or Section Valve Port. If using a PinPoint III Lite hub, adapters can be used to splice ignition power into the ISOBUS harness.

## PinPoint III Hub and Controller-X Connections (500kb):

To utilize the high-speed protocol, a CAN/Serial module (Capstan P/N: 123200-013) is required.

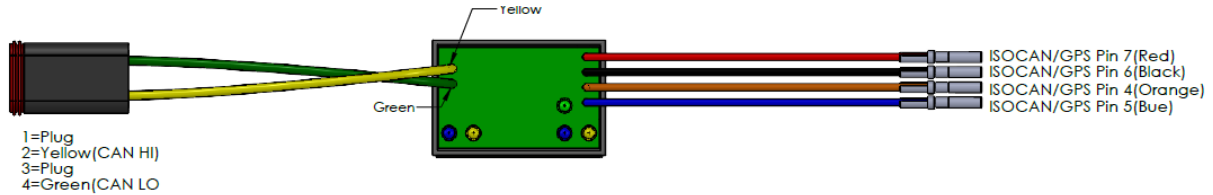

Figure 3 – CAN/Serial Module (123200-013)

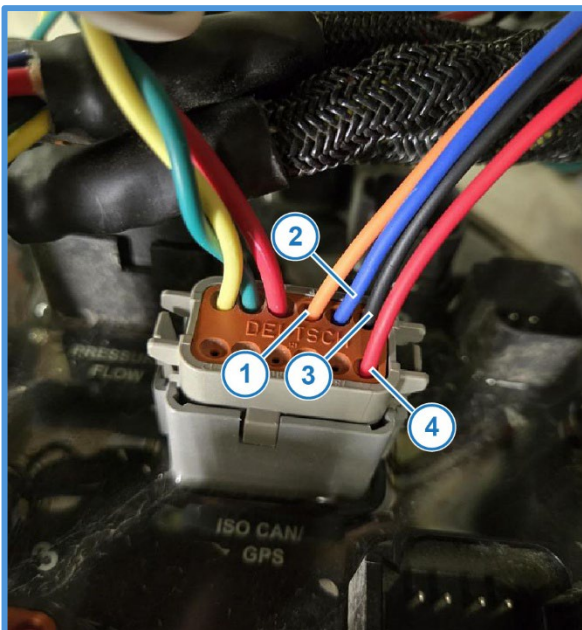

Figure 4 - CAN/Serial Module Pin Locations in PPIII Hub

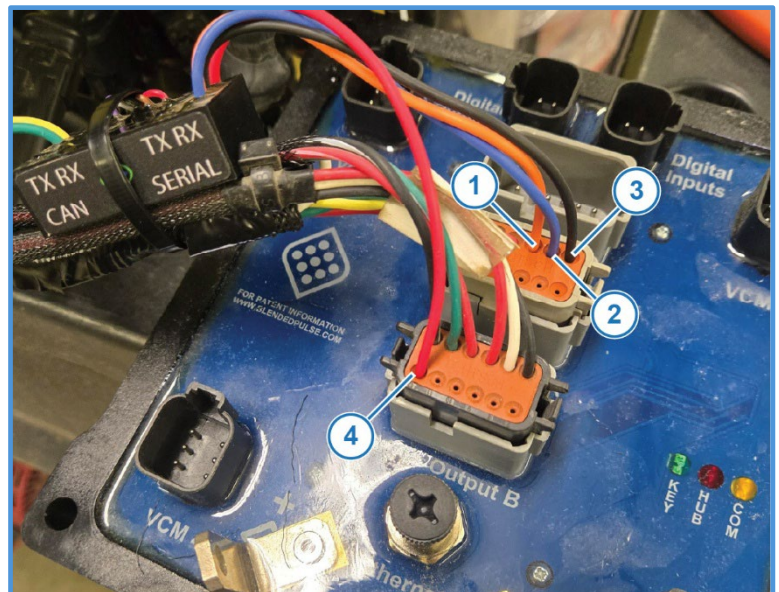

Figure 5 - CAN/Serial Module Pin Locations in PPIII Lite Hub

The CAN/Serial module is pinned into the PinPoint III Hub ISOCAN/GPS or I/O B on the PinPoint III Lite as shown:

1. Orange – Pin 4 (RS232 TX)
2. Blue – Pin 5 (RS232 RX)
3. Black – Pin 6 (Ground)
4. Red – Pin 7 (Power)

**Note:** If hub is a PPIII Lite (**Figure 5**), the red power wire will plug into Pin 12 of I/O B.

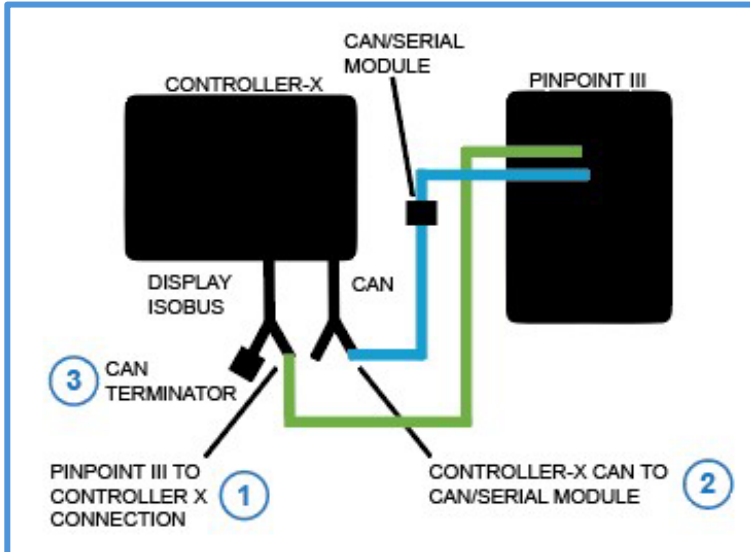

Figure 6 - CAN/Serial Module to Controller-X CAN Connections

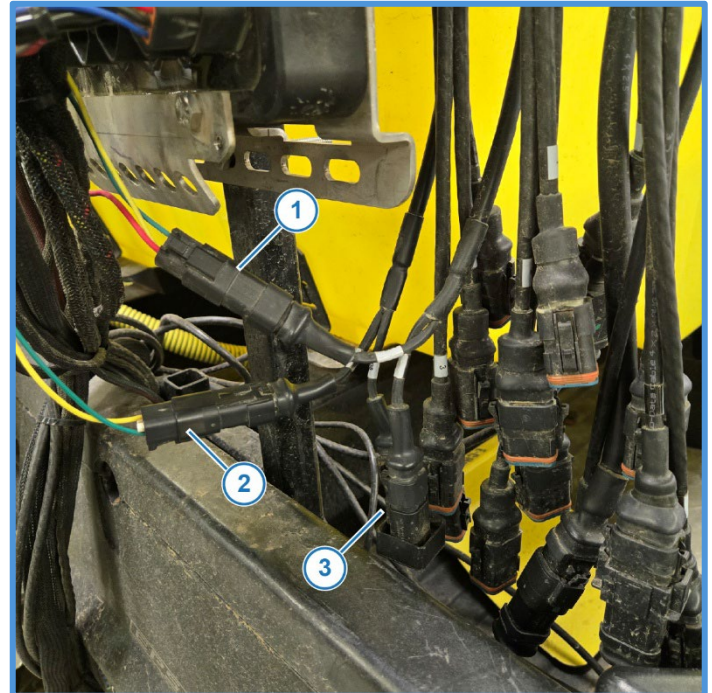

Figure 7 - PinPoint III ISOBUS connection to Controller-X Display ISOBUS

Figures 6 and 7 above identify the required connections that need to be made for the systems to communicate.

1. The CAN/Serial Module (**Figure 5**) should already be installed from the previous procedure
2. From the PinPoint III chassis harness, remove the CAN terminator and connect the Display BUS connection here (**Figures 6 & 7, Item 1**). **Ignition power is required here.**
3. Locate the Controller-X spray CAN harness labeled CAN (**Figures 6 & 7, Item 2**)
4. Connect the 4-Pin Deutsch plug from the CAN/Serial Module to the 4-Pin Deutch receptacle on the CAN harness. An extension to reach it may be required.
5. Reconnect the CAN terminator removed earlier and plug into the remaining connection on the Display ISOBUS connection (**Figures 6 & 7, Item 3**).

## Line Drawings:

### 250k Bus Connections:

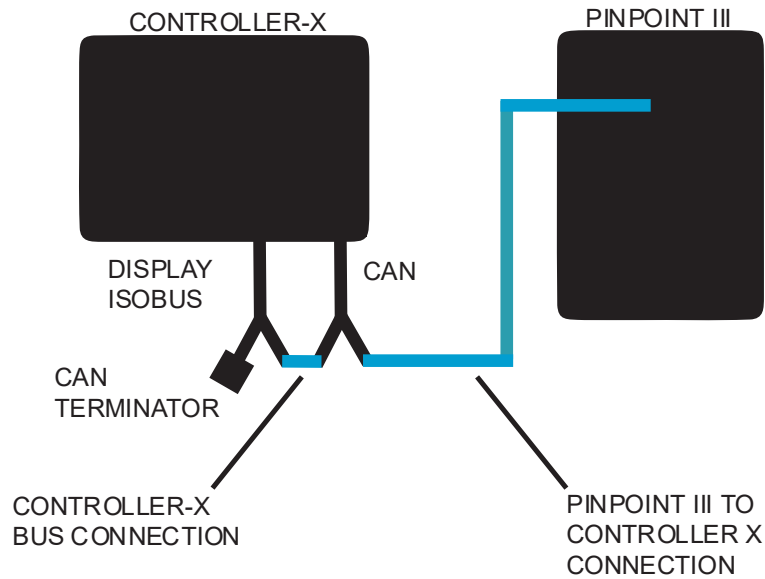

### 500k Bus Connections:

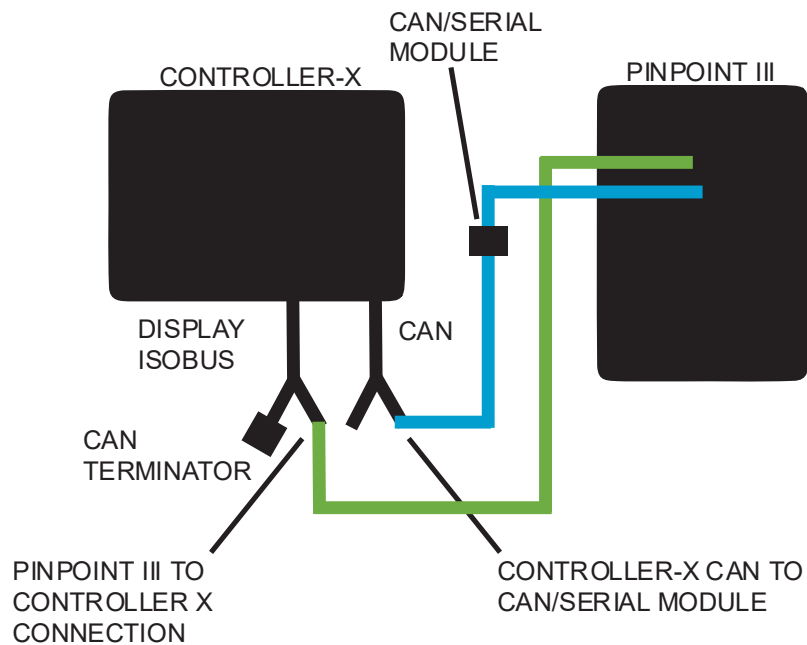

## System Setup:

**IMPORTANT: Set up PinPoint III settings completely before enabling Spot Spray.** Visit <https://capstanag.com/pinpoint-iii-envelop/> under **Resources** tab for manufacturer specific setup instructions.



After all appropriate connections have been made, turn on the machine and allow the systems to boot. Upon loading the PinPoint III VT, complete the following:

1. Tap the Wrench on the PinPoint III VT and navigate to: Initial Setup > Configuration > Option 23: Spot Spray > Enable
2. Navigate to Initial Setup > Configuration > Option 16: Software Restart

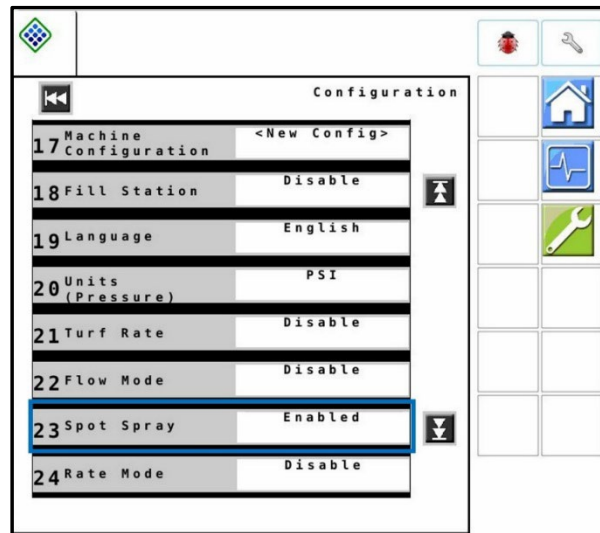

3. After PinPoint III VT has returned, turn off ignition power and wait for battery to disconnect or trip the breaker powering each ECU and reenergize

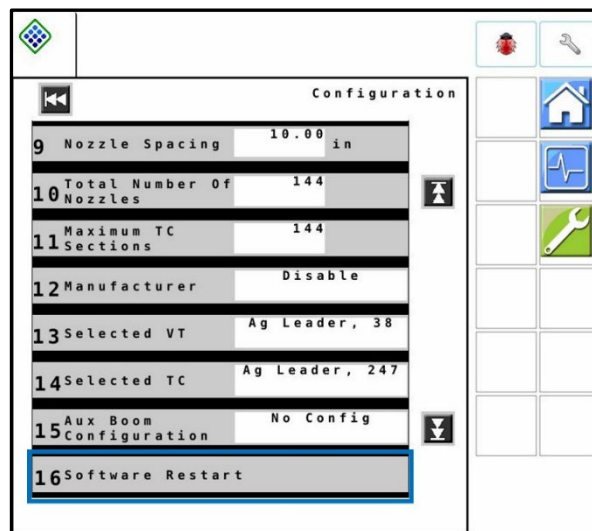

4. On the PinPoint III Home screen, select:
  - a. Target Rate using  $R_{TC}$  or  $R_2$
  - b. Target Pressure using  $P_1$  or  $P_2$
  - c. Enter a Test Speed by tapping the area below MPH or KPH
  - d. Turn on the machine's Master and Section Switches

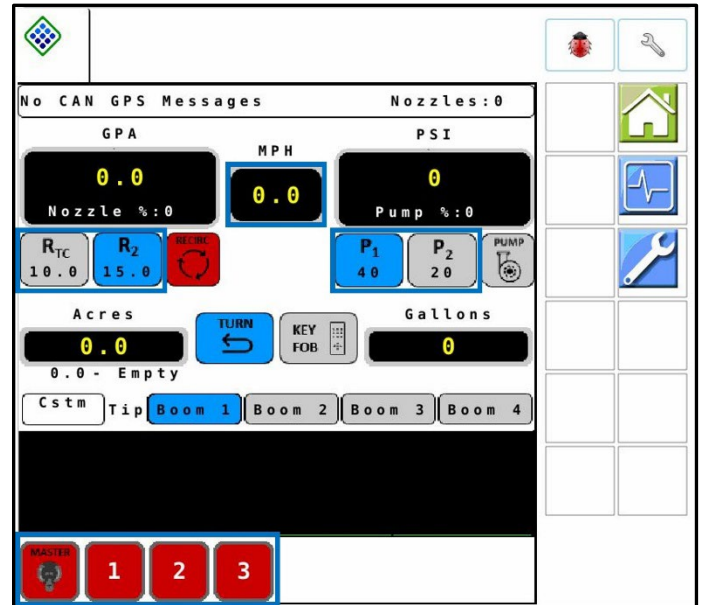

5. On the Carbon Bee VT, tap the Heartbeat Icon (Magnifying Glass icon in previous software) and tap the Spray Test button on-screen

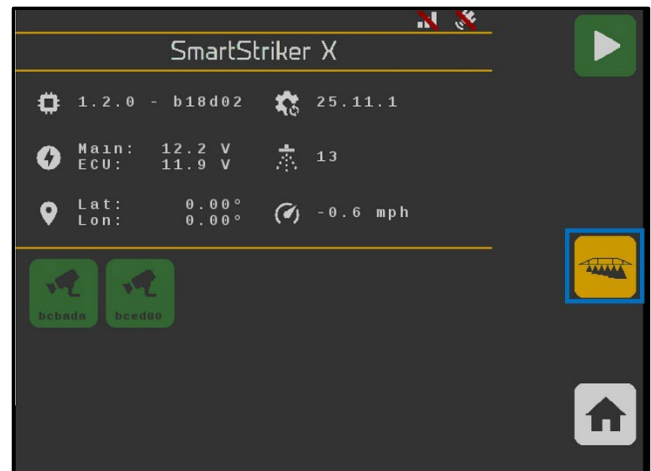
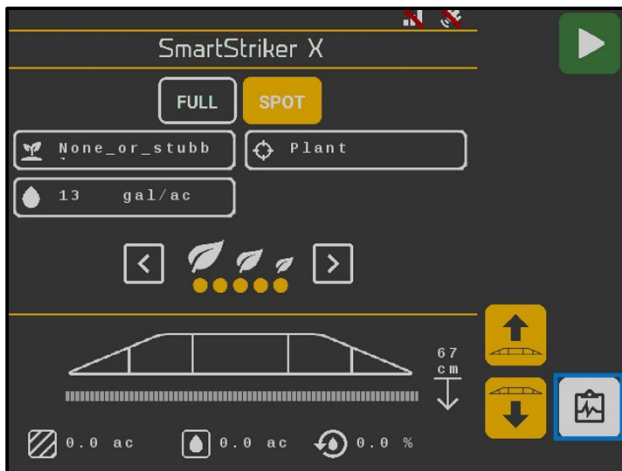

6. Nozzles should cycle one at a time from left to right
  - a. This is a good double-check that the VCMs are oriented on the boom correctly
7. Ensure both ECUs have valid GPS
8. System is ready to spray

## Resources:

### **CAN/Serial Module LED Status Light Explanations:**

<b>LED Location</b>	<b>Color</b>	<b>Label / Function</b>	<b>Indicates</b>
<b>Left Side (below CAN wires – Yellow/Green)</b>	Blue	<b>CAN TX</b>	Transmission of CAN data packets from the adapter onto the 500 k/b Spot Spray CAN bus.
	Yellow	<b>CAN RX</b>	Reception of CAN data packets from the Spot Spray CAN bus.
<b>Right Side (below Serial wires – Red/Black/Orange/Blue)</b>	Blue	<b>Serial TX</b>	Outgoing RS-232 serial communication from the adapter.
	Yellow	<b>Serial RX</b>	Incoming RS-232 serial communication to the adapter.
	Green	<b>Module Power</b>	Power is present and the adapter is active.

**NOTE:** If systems are communicating properly with one another, each pair of Blue/Yellow LEDs will blink rapidly in unison.