



N-Vision™

Anhydrous Ammonia Sentry

For use with:
Cab Box

Operator Manual



Thank you for your business!

At CapstanAG, our goal is to redefine the way people do their chemical application. Our PWM control systems have been setting the bar for maximum productivity for more than 20 years. Our focus on performance, support, and education have dramatically changed the landscape of agricultural chemical application.

CapstanAG specializes in creating proprietary systems for the agricultural industry, primarily focusing on chemical and fertilizer applications. Our inventive process involves research, engineering, design, and lab and field testing.

Service Contact Information

If a problem occurs with your system that cannot be corrected with the information in this manual, please contact your dealer for service and technical assistance. If further assistance is needed, contact CapstanAG.

System Purchased: _____

Dealer: _____

Contact: _____

Phone: _____

Address: _____

City,State/Province, Zip: _____

Factory Service/Repairs

CapstanAG

4225 S.W. Kirklawn Ave. | Topeka, KS 66609

Hours: 8:00 a.m. to 4:00 p.m. CST

Toll-free number: (855) 628-7722 | Fax: (785) 232-7799

CapstanAG.com | CapstanAG.ca

prodsupport@capstanag.com

Contents

Chapter 1: Introduction.....	5
This Manual.....	5
System Identification.....	5
Controller Serial Number Location.....	5
LCD Controller Display Serial Number Location.....	6
Chapter 2: Safety.....	7
Signal Words.....	7
Safety Signs.....	7
Pressurized Fluid Lines.....	8
Personal Protective Equipment.....	8
Battery Safety.....	8
Chemical Safety.....	8
Emergency Safety.....	8
Chapter 3: Warranty.....	9
Limited Warranty.....	9
Chapter 4: Installation and Setup.....	11
Install on the Toolbar.....	11
Install the Tractor Harness (LCD Controller Display Harness).....	13
Chapter 5: Operation.....	15
How N-Vision™ Works.....	15
LCD Controller Display Identification.....	16
Chapter 6: Maintenance.....	17
Filtration Bag.....	17
Replace the Filtration Bag.....	17
Chapter 7: Troubleshooting.....	21
Troubleshooting Chart.....	21
Chapter 8: Schematics.....	23
Fall 2018 and after.....	23
System Wiring Diagram.....	23
Early 2018 and before.....	24
System Wiring Diagram.....	24
Parts List.....	25

Component Identification.....	29
Index.....	31

Chapter 1: Introduction

This Manual

This manual includes operation, maintenance, and installation information for the system you purchased.

Make sure that all personnel have read this manual and that they thoroughly understand the safe and correct operation and maintenance procedures. Failure to do so could result in personal injury or equipment damage.

This manual should be considered a permanent part of your system and should remain with the system at all times and when you sell it.

Right and left sides of the system are determined by facing the direction of forward travel of the machine on which the system is installed.

The information, screenshots, and other illustrations were correct at the time of publication. Changes can occur without notice.

This manual contains important information on how to safely and correctly install, operate, and maintain CapstanAG products. These instructions will help keep personnel safe, reduce downtime, and increase the reliability and life of the equipment, its components, and related systems.

Review the safety information in the manual(s) from the Original Equipment Manufacturer (OEM).

Follow the instructions (in this manual) and in the OEM manual(s) for each step, to make sure that work conditions in and around the OEM equipment are safe.

It is important for all individuals working with chemicals to understand the potential risks, necessary safety precautions, and proper response in the event of accidental contact.

Review the OEM manual(s) for chemical safety information.

Read, understand, and review the procedures in this manual and OEM manual(s). Use the Safety Data Sheets (SDS) and the required Personal Protective Equipment (PPE) for hazardous chemicals.

Please keep this manual and all enclosed documentation in an accessible location known to all operators, installation, and maintenance personnel.

If you do not understand the CapstanAG equipment after reading this manual, please obtain the proper training before working with equipment, to make sure that your own safety, as well as your co-workers' safety, is maintained.

Do not attempt to operate any equipment or system until you completely understand why, when, and how it operates. If you are uncertain after studying this manual, please contact CapstanAG.

System Identification

Controller Serial Number Location

The serial number for the controller is on a decal on the outside of the controller.

The serial number is also part of the SSID.

LCD Controller Display Serial Number Location

The serial number for the LCD controller display is on a decal on the back of the display.

Chapter 2: Safety

Signal Words



DANGER: Indicates an imminent hazard which, if not avoided, will result in death or serious injury. This signal word is limited to the most extreme situations, typically for aircraft components that, for functional purposes, cannot be guarded.



Warning: Indicates a potential hazard which, if not avoided, could result in death or serious injury, and includes hazards that are exposed when guards are removed. It may also be used to alert against unsafe practices.



CAUTION: Indicates a potential hazard which, if not avoided, may result in minor or moderate injury. It may also be used to alert against unsafe practices.

Important: This is used to draw attention to specific information that is necessary for the operation, setup, or service of the system.

Note: This is used for additional information that can help understand or operate the system.

Safety Signs



Figure 1:

The HCS aligned its provisions with the United Nations’ Globally Harmonized System (GHS) Classification and Labeling of Chemicals in 2012. This is a GHS safety label example for a chemical hazard.

These labels and safety messages warn all personnel about hazardous chemicals or potentially unsafe chemical conditions that may exist while working around agricultural application equipment.

CapstanAG add-on application systems for OEM and retrofit agricultural application equipment (booms and toolbars) may contain HCS pictographs and GHS safety labels and safety signal word messages.

Pressurized Fluid Lines

Do not heat by welding, soldering, or using a torch near pressurized fluid lines or other flammable materials. Pressurized lines can accidentally burst when too much heat is present.

Personal Protective Equipment

Wear close-fitting clothing and the correct personal protective equipment (PPE) for the job. See the specific chemical manufacturer documentation or other information for correct PPE.

Battery Safety

Use the procedure in the appropriate agricultural equipment manual for connecting, disconnecting, and jump-starting the machine's battery.

Keep sparks and flames away from the battery. Battery gas can explode and cause serious injury. Do not smoke in the battery charging area.

Remove jewelry, which might make electrical contact and create sparks.

Chemical Safety

Chemicals used in agricultural applications can be harmful to your health and/or the environment if not used correctly. Always follow all label directions for effective, safe, and legal use of agricultural chemicals.

Emergency Safety

Fire extinguishing systems must meet the applicable OSHA requirements, and all users of portable/ fixed fire suppression equipment must know the types, limitations, and proper uses of this equipment; including hazards involved with incipient stage firefighting.

Keep emergency numbers for doctors, ambulance service, hospital, and fire department near your telephone.

Know the location of fire extinguishers and first aid kits and how to use them.

Examine the fire extinguisher and service the fire extinguisher regularly.

Follow the recommendations on the instructions plate.

Very small fires can be put out (extinguished) with a fire extinguisher. Use an appropriate method to extinguish a fire (water for paper fires, and chemical extinguishers for electrical or chemical fires).

Chapter 3: Warranty

Limited Warranty

What does the Limited Warranty cover?

The ultimate purchaser/user (“you”), by acceptance of seller Capstan Ag Systems, Inc.’s, (“our,” “we,” or “us”) product, assume all risk and liability of the consequences of any use or misuse by you, your employees, or others.

All replacement components furnished under this warranty, but shipped before the failed component is returned for evaluation, will be invoiced in the usual manner and warranty adjustments will be made after the component claimed to be defective has been returned to and inspected and deemed defective by us at our factory.

Upon determining that a component has failed under warranty, the repaired component or replacement component, furnished under this warranty, will be shipped at our expense, to your location. We will credit you an amount equal to the incoming freight you paid. We shall not be responsible for installation costs. (You shall be responsible for all customs and brokerage fees for all international transactions.)

If the component does not prove to be defective, you shall be liable for all freight, inspection, and handling costs. In no event will any claim for labor or incidental or consequential damages be allowed for removing or replacing a defective product. Warranty will be denied on any component which has been subject to misuse, abuse, accidents, or alterations, or to improper or negligent use, maintenance, storage, transportation, and handling.

Our liability under this warranty, or for any loss or damage to the components whether the claim is based on contract or negligence, shall not, in any case, exceed the purchase price of the components and upon the expiration of the warranty period all such liability shall terminate. The foregoing shall constitute your exclusive remedy and our exclusive liability.

The terms of this warranty do not in any way extend to any product which was not manufactured by us or one of our affiliates.

While necessary maintenance or repairs on your CapstanAG product can be performed by any company, we recommend that you use only authorized CapstanAG dealers. Improper or incorrectly performed maintenance or repair voids this warranty.

The foregoing warranty is exclusive and is in lieu of all other warranties expressed or implied. We shall not be liable for any incidental or consequential damages resulting from any breach of warranty.

Your exclusive remedy for breach of warranty shall be repair or replacement of defective component(s): Provided, if the component(s) are incapable of being repaired or replaced, your exclusive remedy shall be credit issued, but such credit shall not exceed the purchase price of the components.

On any claim of any kind, including negligence, our liability for any loss or damage arising out of, or from the design, manufacture, sale, delivery, resale, installation, technical direction of installation, inspection, repair, operation of use of any products shall in no case exceed the purchase price allocable to the components.

In no event, whether as a result of breach of contract or warranty or alleged negligence, shall we be liable for incidental or consequential damages, including, but not limited to: personal injury, loss of profits or revenue, loss of use of equipment or any associated equipment, cost of capital, cost of substitute equipment, facilities or services, downtime costs, environmental damage, crop losses, or claims of customers of you for such damages.

What is the period of coverage?

We warrant to you that our products are free from defects in material and workmanship in normal use and service for a period of one year from date of purchase.

How do you get service?

Our obligation under this warranty shall be limited to the repairing or replacing at our option, the component which our inspection discloses to be defective, free of charge, return freight paid by us, provided you: (i) Notify us of defect within thirty (30) days of failure; (ii) Return the defective component to us, freight prepaid; (iii) Complete the Owner Registration Form and returned it to us; and (iv) Establish that the product has been properly installed, maintained and operated in accordance with our instructions or instructions contained in our operations or maintenance manuals and within the limits of normal usage.

Any claim for breach of our warranty must be in writing addressed to us and must set forth the alleged defect in sufficient detail to permit its easy identification by us. All breach of warranty claims must be made within thirty (30) days after expiration of the warranty period, which is applicable to the defective product. Any breach of warranty claim not timely made will not be honored by us and will be of no force and effect. Any component that needs to be repaired or evaluated for warranty has to be authorized before return. Contact the factory (785-232-4477) to get a Return Materials Authorization (RMA #). This helps to track the part coming into the factory for repair or replacement.

Before returning any component to the factory, clean the component as well as possible to remove any dirt or chemical residue. Components received at the factory that are not clean will be returned and warranty denied.

After receiving your RMA #, package the part, making sure to include the RMA #, customer's name, your address and phone number and description of problems or failure. Then ship to:

Capstan Ag Systems, Inc.

Attn: Warranty/Repair

4225 SW Kirklawn Ave.

Topeka, KS 66609

Phone: (785) 232-4477 | Fax: (785) 232-7799

Hours: 8 am to 4:30 pm CST

How does state law relate to this Limited Warranty?

Some states do not allow limitations on how long an implied warranty lasts, so the above limitation may not apply to you.

Some states do not allow the exclusion or limitation of incidental or consequential damages, so the above limitation or exclusion may not apply to you.

This warranty gives you specific legal rights, and you may also have other rights which vary from state to state.¹

¹ Rev. Date 7/15/2014

Chapter 4: Installation and Setup

Install on the Toolbar

1. Install the mounting bracket to the two “L” brackets using six of the supplied 1/2-12 x 1.5 bolts, M12 flat washers, and 1/2-13 nuts.
Important: Near the rear of the toolbar, center the assembly as centered as possible.
Important: Use correct lifting equipment to install this assembly.
2. Install U-bolts (not supplied) through the “L” brackets on the toolbar.
3. Lift the housing assembly onto the mounting bracket.
4. Rotate the housing assembly to the position that works for your application.
5. Install the housing to the mounting bracket assembly with four of the supplied 1/2-12 x 1.5 bolts, M12 flat washers, and 1/2-13 nuts.
6. Remove all plastic plugs from the housing inlets.
7. Install the 2-inch steel plugs into any ports that are not being used.
8. Install the inlet reducer(s) or fitting(s).
Important: The inlet hose should be coming from the breakaway into any of the lower two 2-inch inlet ports.
Recommendation: Use both thread sealant tape and pipe thread sealant.
9. If injection is desired:
 - a) Remove the 3/8-inch plug from the port.
 - b) Use this port to install the check valve and fittings.
10. Remove all plastic plugs from the housing outlets.
11. Install the 2-inch steel plugs into any ports that are not being used.
12. Install the outlet reducer(s) or fitting(s).
Important: The outlet hoses should go to your metering or distribution device.
Recommendation: Use both thread sealant tape and pipe thread sealant.
13. Install two hose barb fittings into the exit ports of the manifold cap assembly.
14. Install the hoses to the individual ports.
15. Install a hose clamp on each hose.
Important: These vapor lines must be put into double tube knives or tied into the outlet line. These lines are for vapor expulsion only.
16. Install the gauge kit into the 1/4-inch port on the tank housing.
17. Connect the two-pin weather pack connectors of the accessory harness to the four PWM valves on the top of the cap assembly.
18. Connect the float switch on the top of the cap assembly to the three-pin weather pack labeled **FLOAT** on the accessory harness.

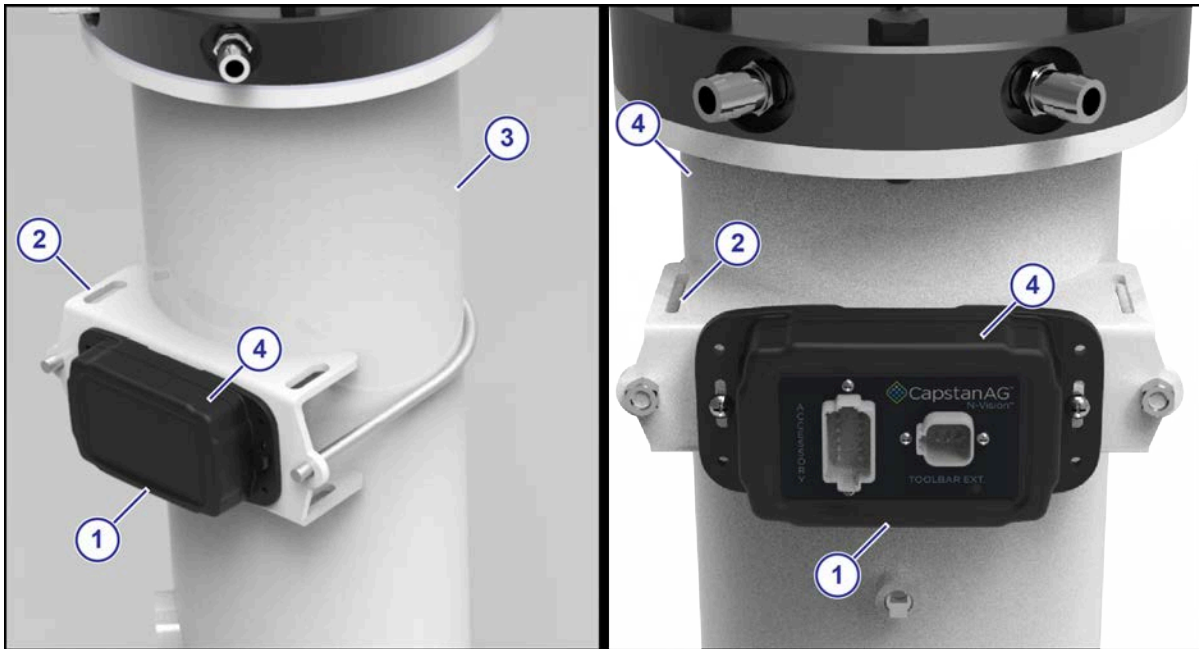

Figure 2:

19. Install the controller (1) to the controller bracket (2) using two screws, washers, and nuts. There are two controller types:

- (3) Early 2018 and before
- (4) Late 2018 and after

20. Install the controller with a clear line of sight facing the back of the machine for an optimal Wi-Fi signal.

The controller houses the Wi-Fi transmitter module. The Wi-Fi module is located in the upper portion (4) and is identified by the controller decal. The Wi-Fi module must have a buffer area around it free of metal for optimal signal reception on the tablet.

The controller can be remotely mounted as long as there is a clear line of sight to the machine, wires are facing down, and the Wi-Fi module is free of metal interference.

21. Connect the six-pin Deutsch adapter harness the six-pin Deutsch connector on the N-Vision™ controller.

The length and part number of the extension harness can vary with the different implements the N-Vision™ system is installed on.

22. Route the adapter harness toward the toolbar hitch.

23. Connect the end of the adapter harness to the six-pin extension harness.

24. Route the extension harness toward the hitch of the toolbar.

25. Attach all the toolbar harnessing to the chassis with cable ties.

The installation of the toolbar is complete.

Continue with the installation of the system on the toolbar.

Install the Tractor Harness (LCD Controller Display Harness)

1. Route the LCD controller display harness from the hitch of the tractor into the cab of the tractor.
2. Connect the 12-pin Deutsch connector to the 12-pin connector on the LCD controller display.
3. Install the LCD controller display in a location that is reachable within the cab of the tractor.

Important: The LCD display controller includes the **POWER** and **RUN** switches and the backup LCD readout.

4. Install the two-pin Deutsch connector of the LCD controller display harness into the power harness.
5. Install the power harness into an available accessory power plug port inside the cab of the tractor.
6. Attach all harnessing to the tractor with zip ties.

Important: The tractor installation is complete. Continue with the installation of the system.

Chapter 5: Operation

How N-Vision™ Works



Figure 3:

- (1) N-Vision™ assembly — Early 2018 and before
- (2) N-Vision™ assembly — Fall 2018 and after

Liquid, gas, and particulates enter the inlets and are pushed upward.

Gaseous liquid travels upward toward the bag filter.

The bag filter catches the ferrous and nonferrous material.

Gaseous liquid travels upward through the separator, where lighter vapor stays above the outlets (level set by the float switch, metered by PWM).

Heavier pure liquid flows down to the outlets and exits.

Important: When the flow is shut off, the heavier ferrous and nonferrous material drops to the catch area below the inlets of the oncoming flow.

LCD Controller Display Identification



Figure 4:

- (1) **POWER** Switch—Turn on/off the system
- (2) **RUN** Switch—When the **RUN** switch is off, the system is in Estop mode, which stops the power to the vapor valves:
 - Disable the **RUN** switch when exiting the cab of the tractor or tending the nurse tanks
 - Disable the **RUN** switch when servicing the system
- (3) LCD Display—System information shown here

Chapter 6: Maintenance

Filtration Bag

It is recommended to replace the filtration bag once a season or after excessive debris is collected. Periodic checks may be necessary with known excessively rusty tanks or after the tanks have been run dry for the first time.

System rates can fluctuate with an excessively dirty filtration bag.

Replace the Filtration Bag

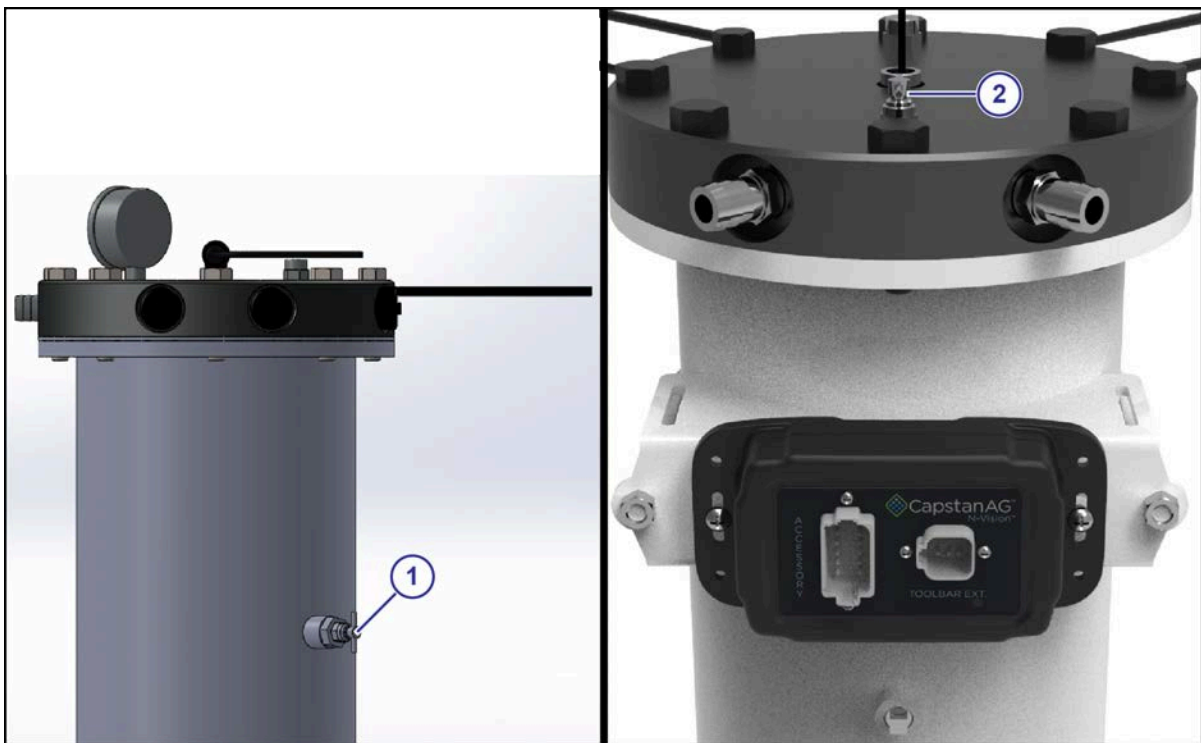

Figure 5:

1. Use the bleeder port on the clean side of the filter to remove pressure from the system.

- (1) Bleeder port — Early 2018 and before
- (2) Bleeder port — Fall 2018 and after

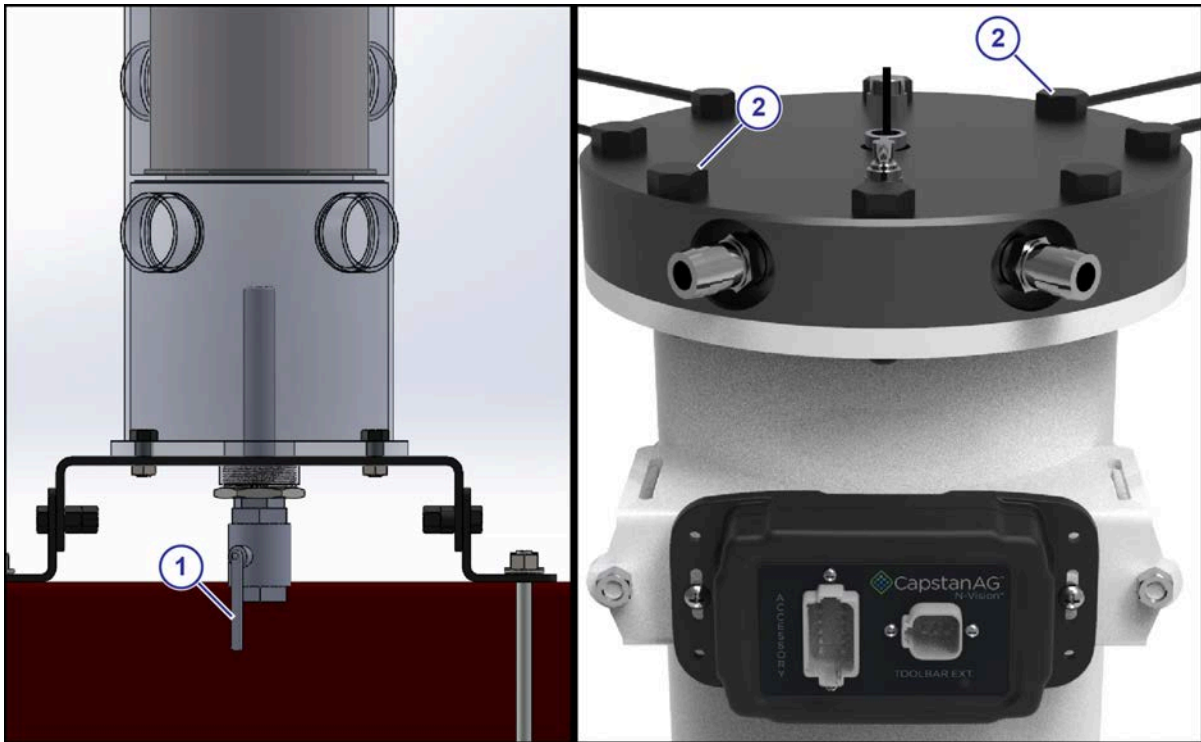

Figure 6:

2. Slowly open the ball valve (1) to remove any remaining product and pressure.
The ball valve should be connected to the ammonia-safe hose and ran away from the valve port.
Make sure that the pressure and product are completely removed from the N-Vision™ housing.
3. Remove the eight 1/2 in bolts (2) from the cap assembly.
4. Remove the cap assembly.
Make sure that you do not damage the float switch when lifting the cap.

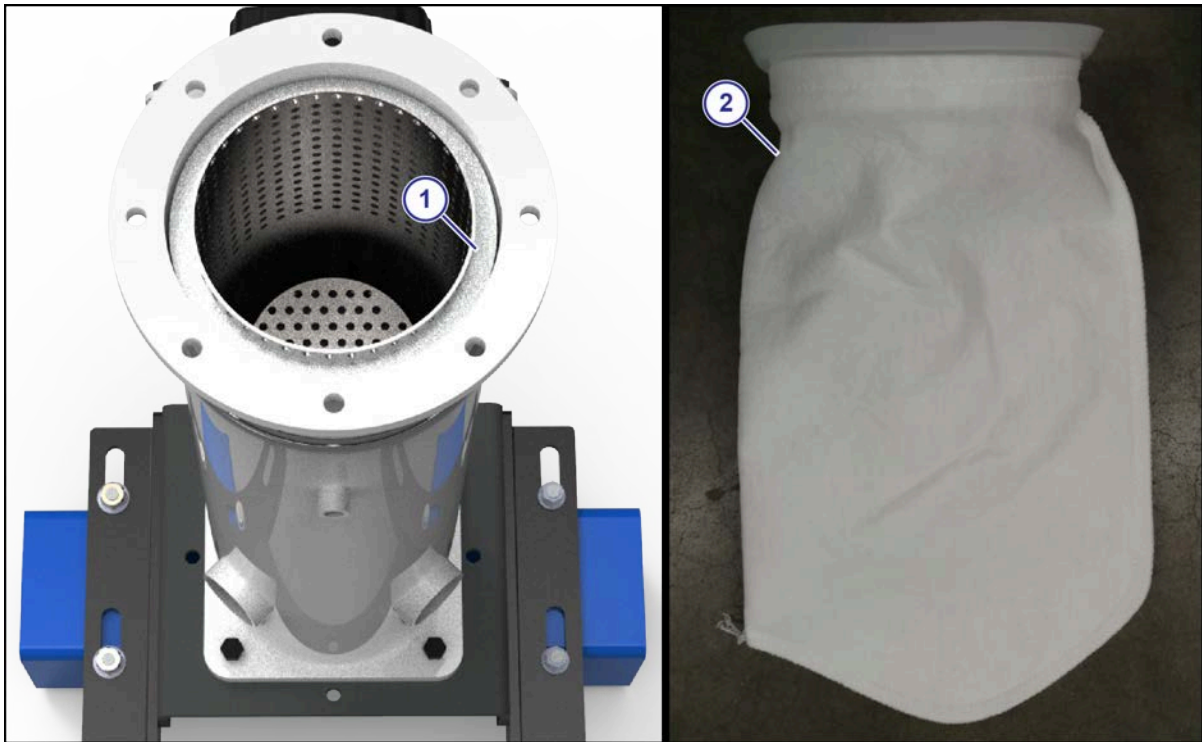

Figure 7:

- 5.** Remove the separator tube assembly (1).
- 6.** Remove and discard the filtration bag (2).
- 7.** Remove the identification tag on the inside of the new bag.
- 8.** Lubricate the steel separator and the inside of the housing with a surface protectant.
- 9.** Install the new filtration bag inside the separator tube.
Make sure that the filtration bag flange is installed onto the separator tube flange.
- 10.** Install the separator tube assembly into the N-Vision™ housing until the separator tube assembly is on the internal seat ring on the inside of the housing.
- 11.** Make sure that there is no damage to the cap O-ring.
- 12.** Install the cap assembly and eight 1/2 in bolts and washers.
- 13.** Torque the bolts to 90 lbf ft (122 Nm).
- 14.** Make sure that the system is sealed and that there are no leaks.

Chapter 7: Troubleshooting

Troubleshooting Chart

Cause	Solution
<p>The system does not reach the liquid level set point.</p> <p>The system continues to try and burp vapor with four valves locked open, even with an appreciable amount of ammonia in the nurse tank.</p> <p>You are going over the capabilities of the application plumbing</p>	<p>Slow the application speed down until the liquid level has a green indication and make sure that the quality of product to the distribution device.</p> <p>To maintain the rate and speed consistently across the application:</p> <ol style="list-style-type: none"> 1. Reevaluate your plumbing configuration and increase plumbing diameter and high flow valves and fittings, if necessary. 2. Try to eliminate tee fittings and elbows where the fittings are not necessary.
<p>When applying ammonia and the system does not reach the liquid level set point, is not able to go above a level point, or is stuck at a liquid level reading.</p>	<ul style="list-style-type: none"> • Make sure that the system is in RUN mode and that the system is not in implement switch mode. • Faulty float switch: Probe the float switch power and ground lines to make sure that the output voltage from the controller to the float switch is 18V. If it is not, then your controller is not functioning properly. <p>For systems built in early 2018 or before, if you do have 18V, bleed the system dry and make sure housing is void of pressure and product. Remove the cap exposing the float switch. Use a multimeter to probe the signal and ground wires and move the float from bottom to top. You should be getting 1V at the bottom and 5V at the top. If you are getting 18V input voltage to float switch and not 1-5V output range, your float switch needs to be replaced.</p> <p>High flow plungers and pressures over 180 psi can cause MOPD issues and not let the valves to open, leaving the N-Vision™ unable to evacuate vapor.</p>

Cause	Solution
The system is struggling to keep the rate correct and is producing excessive vapor	Make sure that the system is in RUN mode. Bleed the system dry and do a check of the filter health to make sure that the bag filtration unit is not excessively dirty or does not need to be replaced. Make sure that there is not a nurse tank related issue: <ul style="list-style-type: none"> • Overflow valve popped • Nurse tank is fully open • Kink in the inlet hose • Break-away issue
Drain valve is not flowing	Open the top bleeder valve and wait until the housing is void of product and pressure. Remove the drain valve and do a check for any obstructions. If obstructed, clean and reinsert. It is also recommended to remove the cap and do a system flush at this time.
Float liquid level is showing at -20%	The controller is not receiving a signal from the float switch. <ul style="list-style-type: none"> • Make sure that the three-pin Weather Pack between the voltage booster and the float switch has a good connection. • Make sure that the signal wire is not broken or have a bad crimp.

Chapter 8: Schematics

Fall 2018 and after

System Wiring Diagram

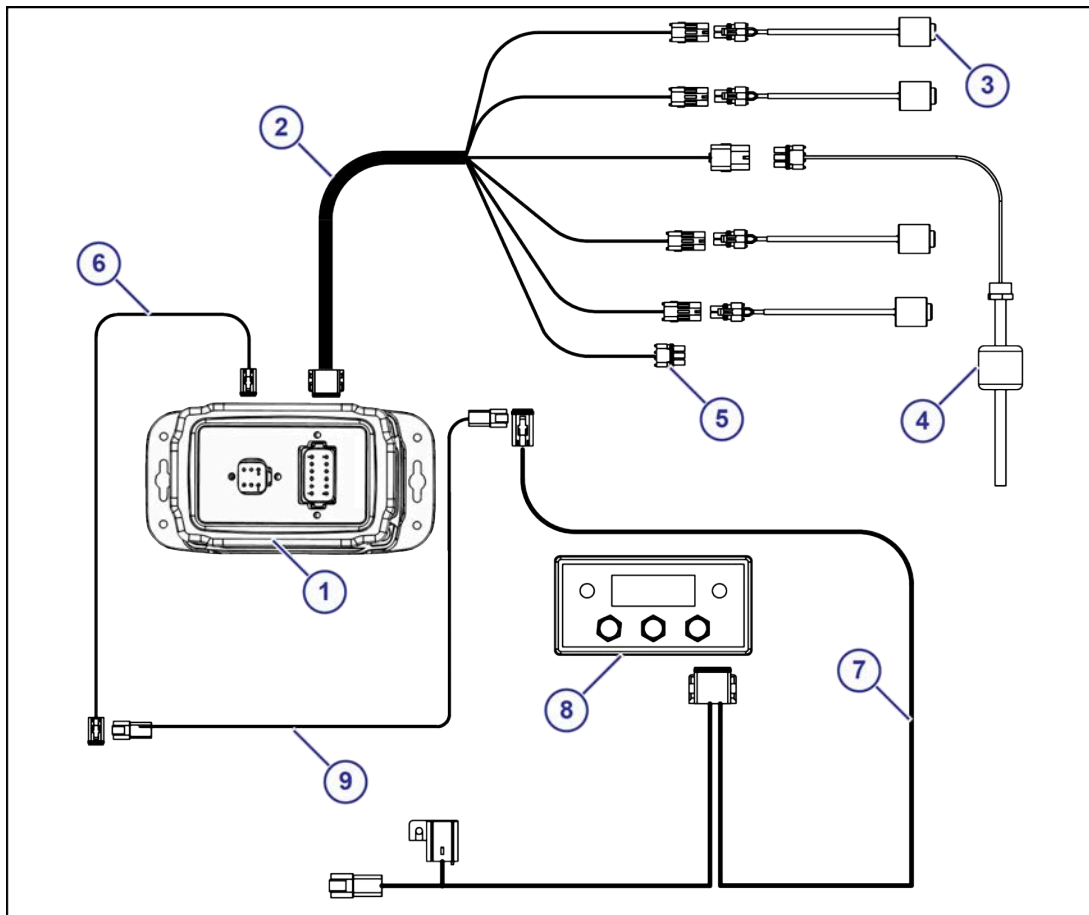

Figure 8:

- (1) Controller
- (2) Accessory Harness
- (3) Valve
- (4) Float
- (5) Implement Connector
- (6) Adapter Harness
- (7) LCD Controller Display Harness
- (8) LCD Display
- (9) Toolbar Extension Harness

Early 2018 and before

System Wiring Diagram

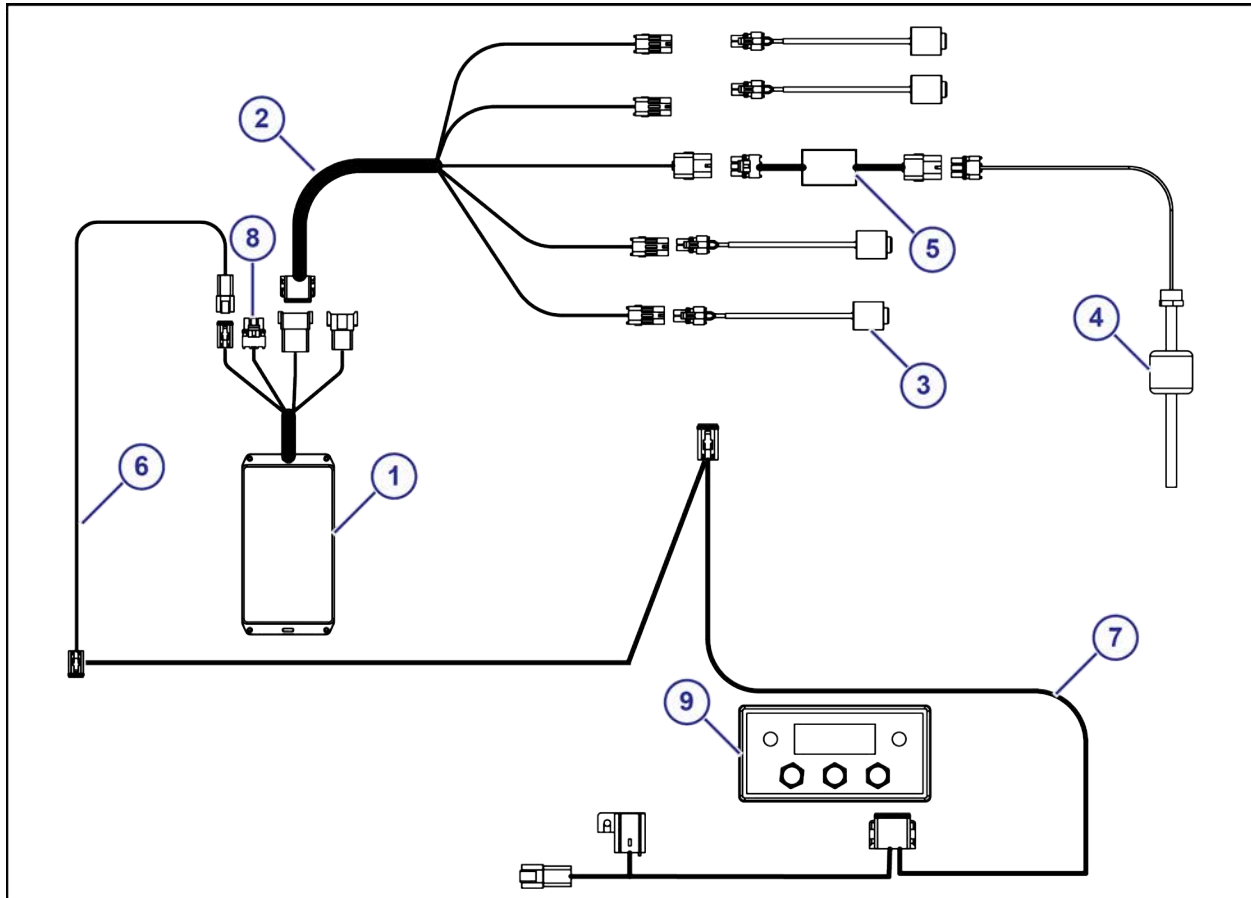

Figure 9:

- (1) Controller
- (2) Accessory (Top Drop) Harness
- (3) Valve
- (4) Float
- (5) 18 V Booster
- (6) Toolbar Extension Harness
- (7) LCD Controller Display Harness
- (8) Implement Switch
- (9) LCD Display

Parts List

Parts Lists for All N-Vision™ Systems

Part Number	Description	Qty
620111-001	M12 Flat Washer	8
620113-002	1/2-13 x 2.5 Bolt	8
620154-001	Anhydrous Ammonia Safety Decal	1
620301-009	2-in Plug	2
620301-100	Tank Assembly	1
620143-001	1/4 NPT Plug Fitting	2
620301-008	1-inch Plug	1
620301-012	Housing Assembly	1
620301-015	MPT 2-inch Plug	4
708000-051	Thread Sealant Tape	1
716008-311	3/8 x 1/4 Bushing	1
620302-005	Cap O-ring	1
620302-100	Cap Assembly	1
620108-001	5/32 NH3 Valve Body	4
620115-001	019 O-ring	4
620116-001	017 O-ring	4
620122-001	350 psi Relief Valve	1
620123-001	Bleeder Valve	1
620302-004	N-Vision™ Cap	1
621022-204	015 O-ring	4
625147-011	12W Coil Assembly	4
715022-901	O-ring Lubricant	1
716190-111	Plunger Assembly	4
620305-001	Separator	1
620305-100P	100 Mesh Filter Bag	1
620308-012	Float Switch Assembly	1
620309-001	N-Vision™ Decal	1
706500-503	3-pin Packard Tower	1

Table 1: Drain Kit — 620304-010

Part Number	Description	Qty
620195-001	1x ½ in Reducer	1
716008-323	½ in Close Nipple	1
620123-002	½ in Full Port Ball Valve	1

Table 2: Gauge Kit — 620304-011

Part Number	Description	Qty
620125-002	4 in/400 psi Liquid Filled Gauge	1
716008-315	¼ in Close Nipple	1
716008-317	¼ in Elbow Fitting	1

Table 3: Mount Kit—620307-015

Part Number	Description	Qty
620307-006	Mount Bracket	1
620307-007	Mounting “L” Bracket	2
620186-002	1/2-13 x 1.5 Flange Bolt	6
620113-001	1/2-13 x 2 Flange Bolt	4
620111-001	M12 Flat Washer	10
620114-001	1/2-13 Hex Flange Nut	10

Table 4: Maintenance Kit — 620304-005

Part Number	Description	Qty
620302-005	Cap O-ring	1
620305-100P	100 Micron Filter	1
716190-111	4-Slot High-Flow Plunger Assembly	4
621022-204	015 Buna O-Ring	1

Parts List—Fall 2018 and After

Table 5: Wiring Package Kit — 620300-102

Part Number	Description	Qty
620300-210	Controller Mount	1

Part Number	Description	Qty
620300-211	Controller Mount U-bolt	1
620303-004	Power Harness	1
620303-005	Cab Display Assembly	1
118603-111	RAM Mount	1
620303-013	Cab Display	1
709031-508	8-32 X 1/2 Pan Screw	4
709031-510	8-32 Nut	4
620303-017	Controller Assembly	1
620303-018	Accessory Harness	1
620303-020	LCD Controller Display Harness	1
709031-908	1/4-20 X 1 1/4 Screw	2
713501-903	1/4-20 Hex Lock Nut	2
713501-905	3/8-16 Hex Lock Nut	2
620303-023	Plug-to-plug Adapter Harness	1
Extension Harness		1
118650-015	15 ft Extension Harness	
118650-020	20 ft Extension Harness	
118650-025	25 ft Extension Harness	
118650-030	30 ft Extension Harness	
118650-035	35 ft Extension Harness	
118650-040	40 ft Extension Harness	

Parts List—Early 2018 and Before

Table 6: Wiring Package Kit — 620300-101

Part Number	Description	Qty
620300-210	Controller Mount	1
620300-211	Controller Mount U-bolt	1
620303-001	Top Drop Harness	1
620303-003	Controller Assembly	1
620303-004	Power Harness	1
620303-005	Cab Display Assembly	1
118603-111	RAM Mount	1

Part Number	Description	Qty
620303-013	Cab Display	1
709031-508	8-32 X 1/2 Pan Screw	4
709031-510	8-32 Nut	4
620303-006	USB Cable	1
620303-012	LCD Controller Display Harness	1
620303-019	18 V Booster	1
713501-905	3/8-16 Hex Lock Nut	2
715040-177	Black Cable Ties	25
620303-020	LCD Controller Display Harness	1
620303-004	Power Harness	1
620303-005	Display Assembly	1
620303-018	Accessory Harness	1
620303-017	Controller Box Assembly	1
620300-210	Controller Bracket	1
620300-211	3/8 in U-bolt	1
713501-905	3/8-16 UNC Hex Nut with K-Lock	2
709031-908	1/4-20 x 1-1/4 Truss Screw	2
713501-903	1/4-20 UNC Hex Nut with K-Lock	2

Component Identification

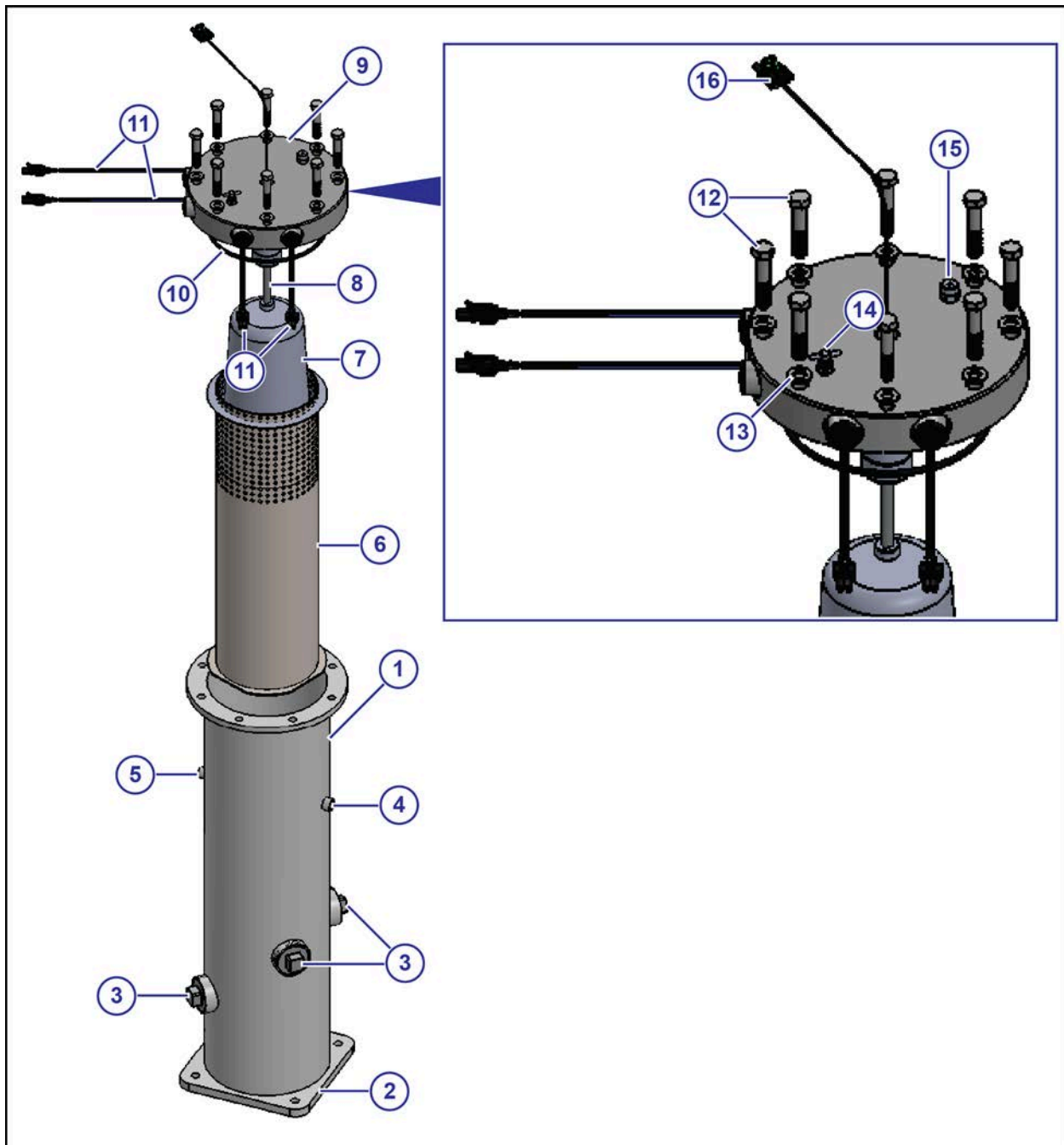

Figure 10:

Item	Part Number	Description	Qty
(1)	620301-012	Tank Housing	1
(2)	620301-008	1 in Plug	1
(3)	620301-009	2 in Plug	4
(4)	620301-011	3/8 in Plug	1
(5)	620143-001	1/4 in Plug	1
(6)	620305-001	Separator Screen Assembly	1
(7)	620305-100P	100 Micron Poly-pro Filter Bag	1
(8)	620308-012	Float Switch	1
(9)	620302-004	Cap Housing	4
(10)	620302-005	Cap O-ring	1
(11)	625147-011	12 W Coil Assembly	4
(12)	620113-002	1/2-13 x 2.5 Flange Bolt	8
(13)	620111-001	M12 Flat Washer	8
(14)	620123-001	Bleeder Valve	1
(15)	620122-001	Pressure Relief Valve	1
(16)	706530-206 and 706500-503	Female Terminal and Male Connector	3 and 1

Index

B

Battery Safety [8](#)

C

Chemical Safety [8](#)

Component Identification [29](#)

Controller Serial Number Location [5](#)

E

Emergency Safety [8](#)

F

Filtration Bag [17](#)

H

How N-Vision Works [15](#)

I

Install on the Toolbar [11](#)

Install the Tractor Harness (LCD Controller Display Harness) [13](#)

L

LCD Controller Display Harness Installation [13](#)

LCD Controller Display Identification [16](#)

LCD Controller Display Serial Number Location [6](#)

P

Parts List [25](#)

Personal Protective Equipment (PPE) [8](#)

PPE (Personal Protective Equipment) [8](#)

Pressurized Fluid Lines [8](#)

R

Replace the Filtration Bag [17](#)

S

Safety Signs [7](#)

Signal Words [7](#)

System Identification [5](#)

System Wiring Diagram [23](#), [24](#)

T

This Manual [5](#)

Toolbar Installation [11](#)

Tractor Harness Installation [13](#)

Troubleshooting Chart [21](#)

W

Warranty [9](#)



Application Systems for Professionals™

prodsupport@capstanag.com | 855-628-7722 | www.capstanag.com

©2021 Capstan Ag Systems, Inc. All Rights Reserved. | All trademarks are owned by Capstan Ag Systems, Inc. This product may be covered by one or more U.S. Patents. For more information go to www.BlendedPulse.com